

L1 is a slide of a stained transverse section through a plant organ.

- (a) (i) Draw a large plan diagram of the region on **L1** indicated by the shaded area in Fig. 2.1. Use a sharp pencil.

Use **one** ruled label line and label to identify **one** vascular bundle.

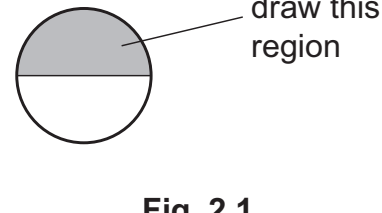

Fig. 2.1

[5]

- (ii) Observe the xylem vessel elements in the organ on **L1**.

Select a line of **four** adjacent xylem vessel elements.

Each xylem vessel element must touch at least **one** other xylem vessel element.

- Make a large drawing of this line of **four** xylem vessel elements.
- Use **one** ruled label line and label to identify the wall of **one** xylem vessel element.

[5]

- (iii) Identify the plant organ on **L1** and give a reason for your answer.

.....
 [1]

- (b) Fig. 2.2 is a photomicrograph of a stained transverse section of the same organ from a different plant to **L1**.

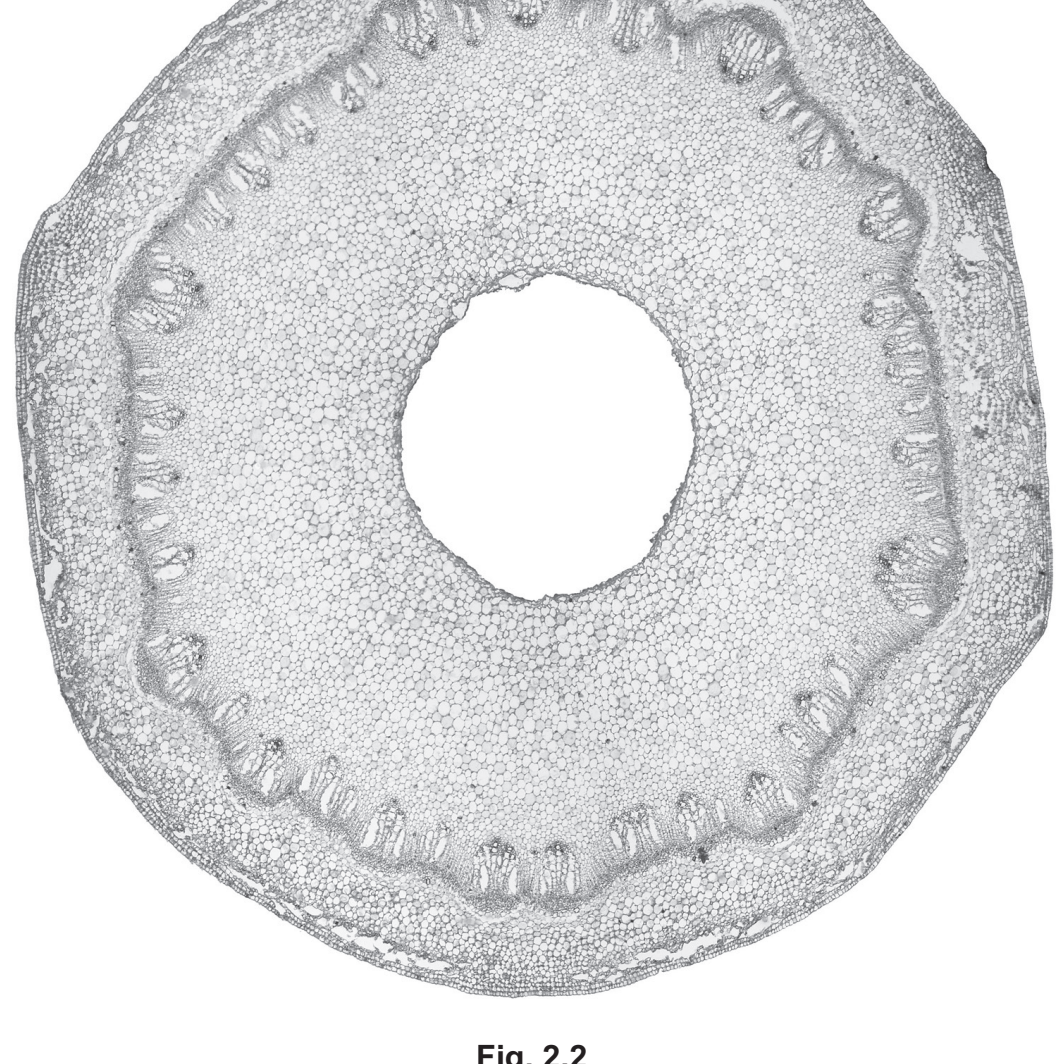

Fig. 2.2

Identify **two** observable differences, other than colour, between the section on **L1** and the section in Fig. 2.2.

Record these **two** observable differences in Table 2.1.

Table 2.1

feature	L1	Fig. 2.2
1		
2		

[3]

- (c) Fig. 2.3 shows a photomicrograph of a stage micrometer scale that is being used to calibrate an eyepiece graticule.

One division, on either the stage micrometer scale or the eyepiece graticule, is the distance between two adjacent lines.

The length of one division on the stage micrometer in Fig. 2.3 is 1.0mm.

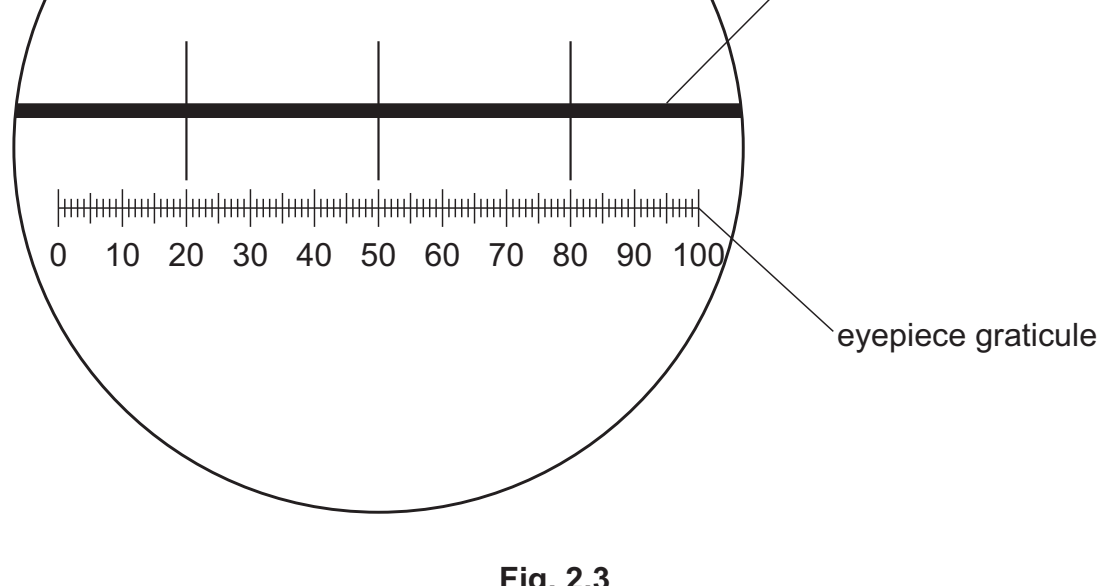

Fig. 2.3

- (i) Calculate the actual length of **one** eyepiece graticule unit shown in Fig. 2.3.

Give your answer in micrometres (μm).

Show your working.

actual length = μm
 [2]

Fig. 2.4 is the same photomicrograph as that shown in Fig. 2.2. This was taken with the same microscope and the same lenses used to take the photomicrograph in Fig. 2.3. The eyepiece graticule has been placed across the width of the tissue.

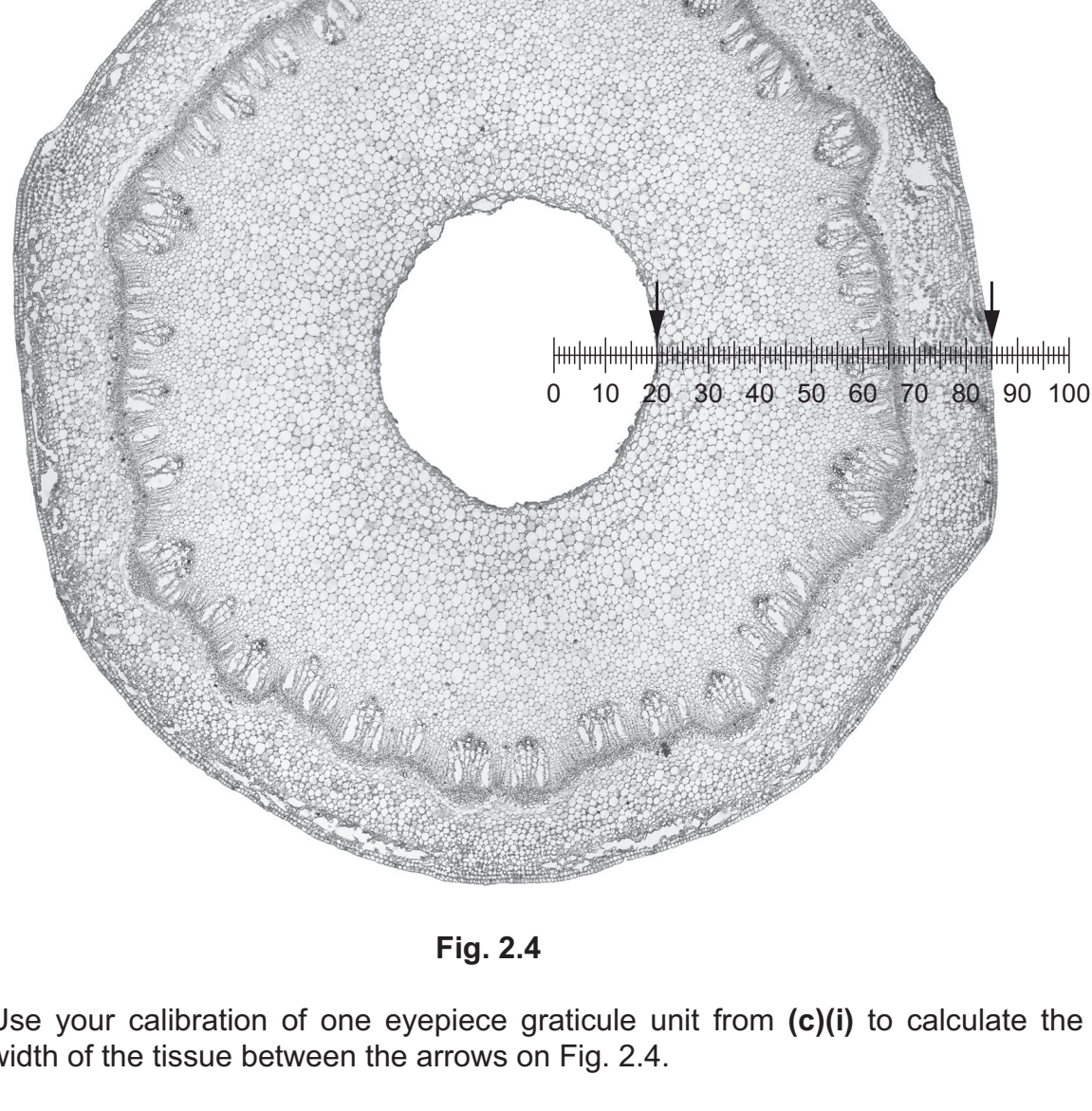

Fig. 2.4

- (ii) Use your calibration of one eyepiece graticule unit from (c)(i) to calculate the actual width of the tissue between the arrows on Fig. 2.4.

Show your working and use appropriate units.

actual width of the tissue between the arrows [2]

- (iii) The width of the tissue in Fig. 2.4 varies. Suggest how you could more accurately calculate the width of the tissue.

..... [1]